

# MD-1 SERIES

## DESK TOP DYNAMIC MICROPHONE

This microphone series is designed for especially high quality audio characteristics and convenient operation. A personalized callplate for the MD-1 is available with your call sign engraved on it. Simply fill out and return the attached coupon to Yaesu Musen, CPO Box 1500, Tokyo, Japan.

### Features

1. A heavy diecast base and bronze element casing make the MD-1 a particularly durable, heavy-duty microphone for base station use.
2. The large dynamic element provides an extremely wide range audio response, and an internal switch is then used to select that portion of the audio spectrum that one chooses to emphasize, attenuating the lower frequencies according to the user's choice.
3. Output impedance may be selected via an internal switch, 600 or 50K ohms.
4. A dual pivoting mechanism allows both horizontal and vertical rotation to accommodate various locations and heights, while the microphone can also be easily separated from the base to provide for those situations where a hand-held microphone is most convenient. (If the microphone is electrically disconnected and used totally independently from the base, only 600 ohms impedance without scanning control is possible.)
5. The base of the MD-1 includes a large PTT switch bar and lock switch, as well as scanning UP, DOWN, and FAST switches.\* The microphone contains a PTT slide switch (only).

### Specifications

#### Type:

Dynamic

#### Frequency Response:

100 Hz – 15 kHz (–6 dB)

#### Sensitivity:

–73 dB at 600 ohms, –56 dB at 50K ohms

#### Directivity Pattern:

Unidirectional (teardrop)

#### Switches:

(Top)

PTT, PTT lock, Scan UP, DOWN and FAST\*

(Bottom)

Audio Tone Response (3 positions)

Position 1: full range

Position 2: –5 dB at 100 Hz

Position 3: –10 dB at 100 Hz

Impedance Selector (600 ohms/50K ohms)

#### Dimensions:

Base: 98 x 160 x 165 mm (WHD)

Microphone: diameter 40.5 x 210 mm

#### Weight:

Base ~ 750g.

Microphone ~ 250g.

\* Some models of the MD-1 series do not include the scanning switches.

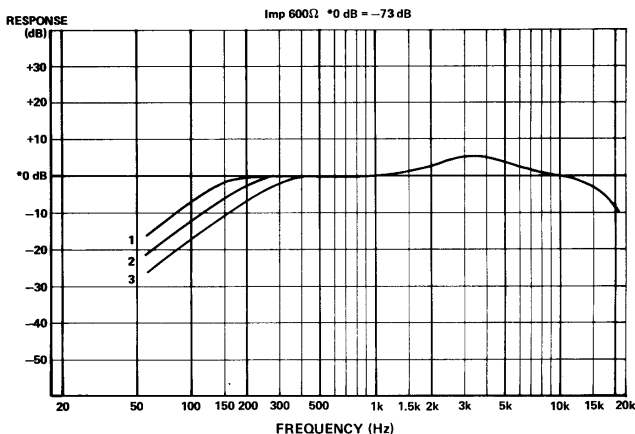

## NAME AND FUNCTION OF COMPONENTS

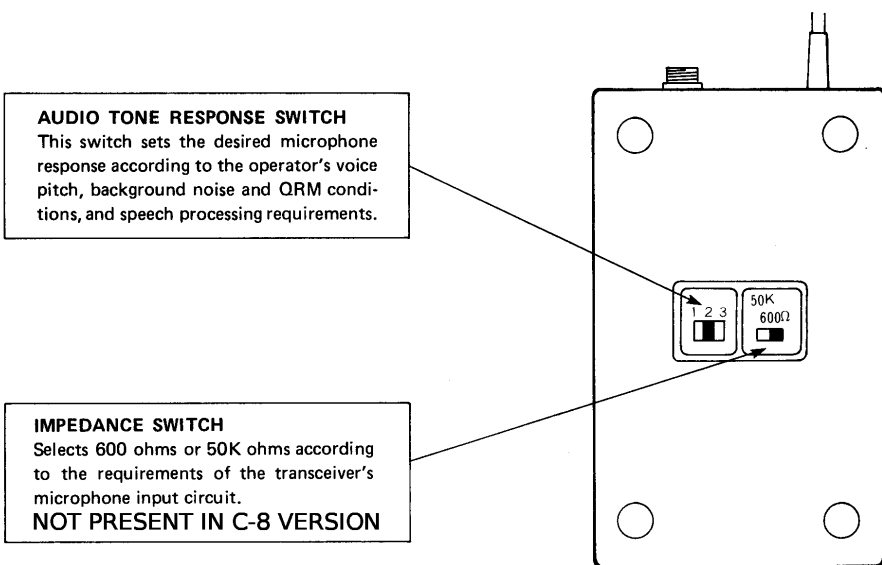
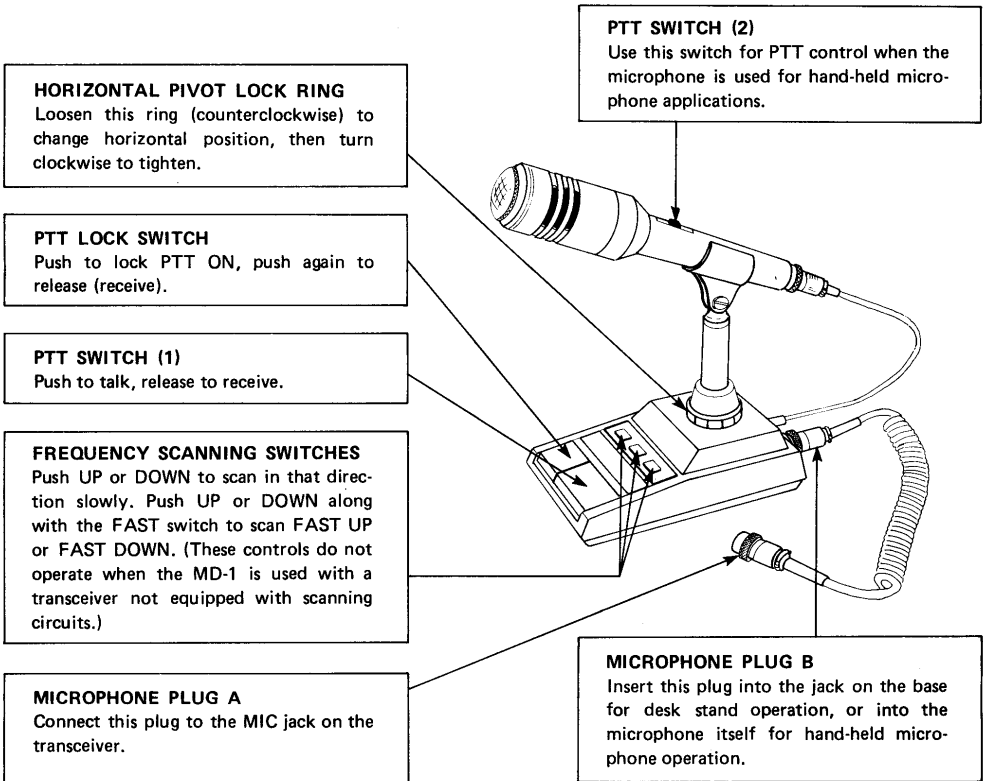

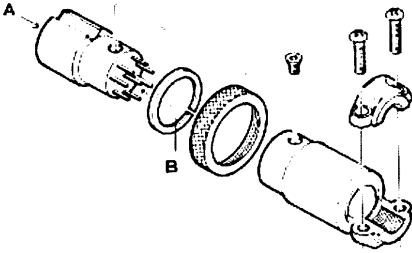

**PLUG ASSEMBLY**



**MD-1B8**

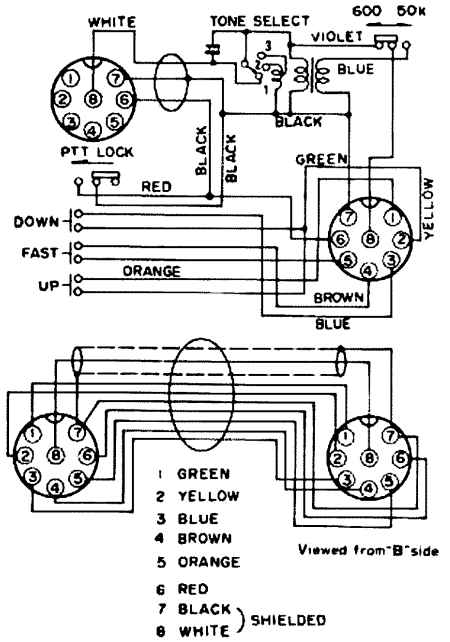
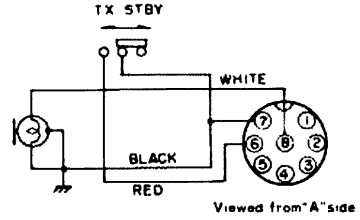

**MII-1B8**

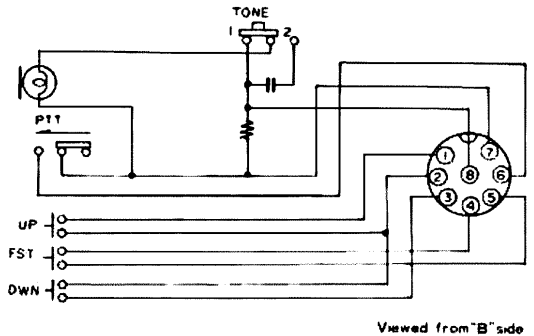

MH-1B8 Hand Mic and MD-1C8 Desktop Mic have 600-Ω impedance, and include UP/DWN scanning buttons and a large PTT switch. The MH-1B8 also has a 2-position transmit audio characteristic selector, while the MD-1C8 has a 3-position selector. Typical audio characteristic plots with the different switch settings are indicated in the graphs below.

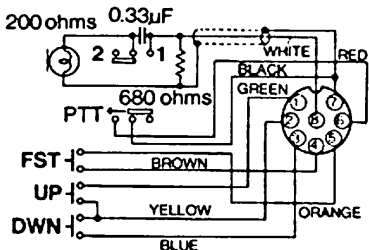

## YAESU MD-1c8

### MH-1 B8

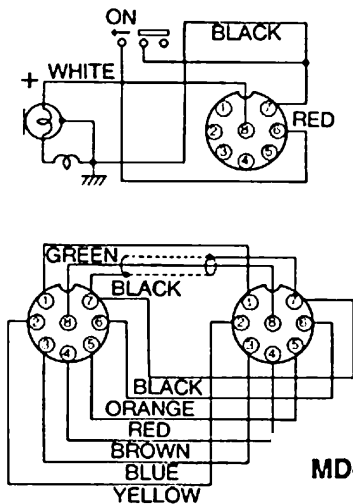
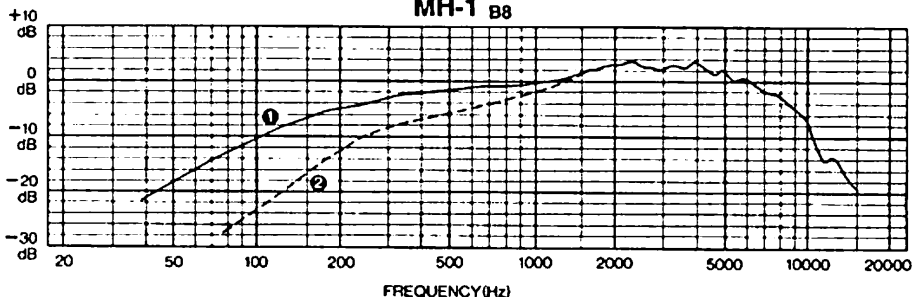

### MD-1 c8

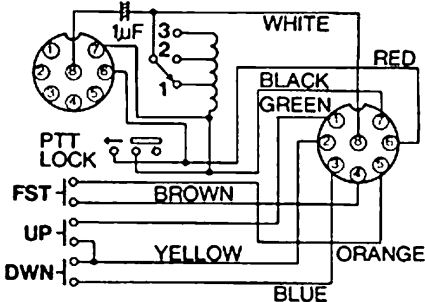

## YAESU MICROPHONE PINOUTS

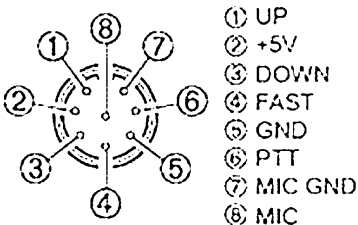

(as viewed from front panel)